

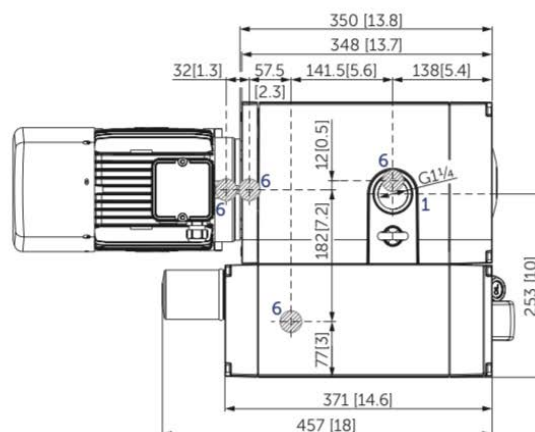

Model: **U 5.71**

SPECIFICATIONS

Volume flow 50 Hz	70 m ³ /h
Vacuum absolute 50 Hz	≤0.1 mbar
Power 50 Hz	1.5 kW
Noise Level 50 Hz	64 dB(A)
Volume flow 60 Hz	84 m ³ /h
Vacuum absolute 60 Hz	≤0.1 mbar
Power 60 Hz	1.8 kW
Noise Level 60 Hz	67 dB(A)
Weight	41 kg without motor

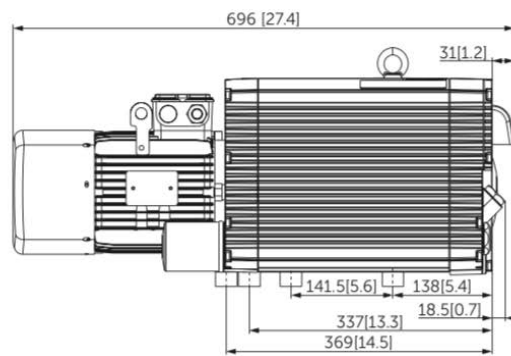
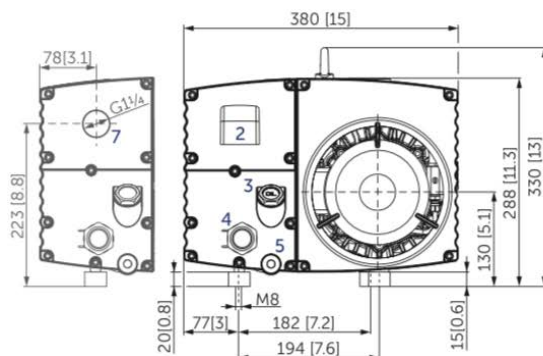

- 1 Vacuum connection (G1¼)
- 2 Exhaust air (diverter)
- 3 Oil filler cap (G¾)
- 4 Oil sight glass (G1)
- 5 Screw plug for oil drain (G½)
- 6 Rubber buffer position
- 7 optional: threaded connector for exhaust air (G1¼)
 - incl. gas ballast valve, non-return valve, oil separator and oil filter
 - The motor illustration may vary
 - Dimensions in mm [inch]